

# Tunnel Reclaim

Instant, Reliable Access to Your Surge Pile

## Constant Feed

Maintain a continuous feed of material to your processing plant.



## Curb Trucks

Decrease your dependency on expensive loaders and workforce.



**AWS**

Certified  
Welders

## Modular Machine

Allows for flexible modifications in the future without replacing the entire system.

**SUPERIOR**

Brand  
Components



**5-year**

Structural  
Warranty

## Flexible Design

Dome or box tunnels; roof or floor mounted vibrating pans and belt feeders.

## Heavy Duty

Our designs are manufactured for equal pressure across the tunnel's entire length.

**2-year**

Complete  
Conveyor  
Warranty



## Featured Superior Brand Conveyor Accessory:

Determined to function, even in some of the most corrosive conditions, our Superior brand take-ups are characterized by broad, strong components.

# Tunnel Reclaim

Box Style Tunnel

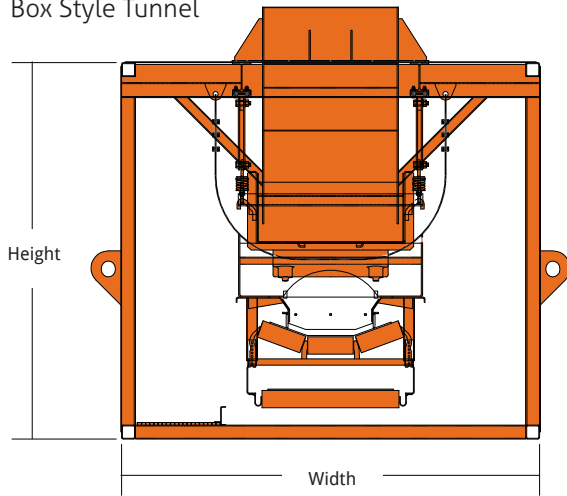

Dome Style Tunnel

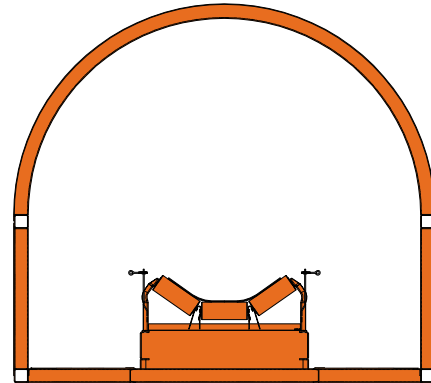

Tunnel Length	Width	Height	Walkways	Standard Lengths	Add'l Increments
8-foot Tunnel Reclaim	8'-0"	8'-0"	One	17'-0" or 51'-0"	34"
10-foot Tunnel Reclaim	10'-0"	9'-0"	One or Two	17'-0" or 51'-0"	34"
12-foot Tunnel Reclaim	12'-0"	9'-6"	One or Two	17'-0" or 51'-0"	34"

